

Confidence Interval Estimation Model of the Theocratic Governmental Restoration

S.L. Nemenzo

Department of Education, Science-Technology-Engineering and Mathematics Faculty, Tisa National High School, Cebu City, Philippines

Author's Mail Id: nemenzo.saul_lloren@yahoo.com, Tel.: (034) 729-0597

Available online at: www.isroset.org

Received: 11/Apr/2021, Accepted: 17/Apr/2021, Online: 30/Apr/2021

Abstract—Human suffering that leads to disappointment opted people to search for a better form of government and finds reasons to believe that it is possible. Motivated by that reason, this study attempts to construct the year interval estimation model of Theocratic governmental restoration by using historical and purposive content analysis of the Bible through conflation structure analogy expert-judgment. The first finding reveals that the form of government before the event of the rebellion of Adam and Eve in the Garden of Eden was the initial stage of the Theocratic form of government. The second finding shows that their rebellion is the fundamental reason of human suffering. The third significant finding depicts that God allows humankind's independent governments only for 6000 years from the year of Adam's rebellion. The fourth finding explains that the restoration of Theocratic government brings restoration of human perfection within 1000 years. Lastly, the model of Theocratic governmental restoration with respect to time is constructed with a representation of two parts such as the 6000 years after the year of Adam's rebellion, which will take place in the year interval of [1975 C.E.–2105 C.E.] or [2021.5 C.E.–2034 C.E.] and the 1000 year of the Christ' reign for restoration towards perfection, which will take place in the year [2975 C.E.–3105 C.E.] or [3021.5 C.E.–3034 C.E.]. It establishes visualization of hope for those people who are disappointed with the world's current system.

Keywords—Estimation Model, Theocratic Government, Restoration

I. INTRODUCTION

Every country has its own strengths and weaknesses in terms of form of governance [1]. There are instances where some of the citizens in a country cannot be accommodated with their needs which may result to human sufferings and dissatisfactions [2]. The solution needed that will show for a better form of government can be likened to the medical field, in a sense that the cure must do more than to address symptoms but must correct underlying causes. The present human government had only used a form of medication that would help us to feel better but could not really address the root causes of our troubles. For example, governments enact laws, install video surveillance, and strengthen police forces to fight against crime. Such measures, though effective to some extent, do not really address underlying causes because the fundamental causes rooted from human behaviors derived from attitudes, beliefs, desires, and poor genetic make-up which treatment can be very difficult to perform [3].

Mankind has been impotent to discover the cure for the destructive traits that lurk within us. For this reason, there are people who would search for a better form of government to the point of approaching God and hope for the arrival of His government [4]. As an example, people usually pray "Our Father, you are in heaven, Holy be your

name. Let your kingdom come. Let your will be done on earth as it is in heaven." Such prayer will show that there are humans who really are looking forward for the arrival of God's form of government. Because of their desperate conditions, they have attempted many times to predict the arrival of real Theocratic government.

Multiple attempts had been made to predict about the restoration of theocratic government which commenced with the operation of judgement day. Sadly, these predictive attempts always lead to disappointments because these were not realized [5]. It is in this connection why this study is initiated with five major objectives. First, to determine the original form of government designed for Adam and Eve before the event of their rebellion. Second, to determine the consequences of their rebellion for themselves and to the rest of mankind. Third, to decipher the length of years God allows mankind to govern themselves. Fourth, to find out the benefits of the Theocratic government restoration. Lastly, to construct the year estimation model of Theocratic governmental restoration.

The attainment of such five objectives will strengthen our hope to believe that human suffering will not last forever and to warn all sorts of people about the incoming great tribulation that will occur either in the year interval of

1975 to 2105 (100% accuracy) or in the year interval of 2021.5 to 2034 (98.82% accuracy). Such predictive attempt will give the entire human-race the chance to make the necessary changes of themselves when they are given the opportunity to know the argumentative genuineness of the consolidated evidence derived from the Bible through this study.

Furthermore, this paper is structurally organized with five sections to facilitate the reading convenience of readers. These sections are introduction, related works, methodology, results and discussions, and conclusions.

II. RELATED WORK

Original Form of Government

The garden story in Genesis 1-3 shows God's orderly creation, climax with the creation of Adam and Eve as a responsible and blessed being, and then the disintegrating work of sin because of disobedience [6]. From the story, one can depict the creator-creation relationship wherein one has higher status than the other. Traditionally, held by the Christian belief that the Genesis is about God from first to last and that the first couple were given responsibility in the form of commandment to have dominion on all things created. All these scenes imply that as Adam and Eve lived in splendor in the Garden of Eden, they accepted God as both their creator and ruler – a divine authority structure [7].

The Consequences of Human Rebellion Against God's Sovereignty

According to the literatures [8,9], God created the first couple, Adam and Eve, to cultivate the earthly paradise and to take care of it with the prospect of living forever. However, an event of rebellion happened. The first couple desired to become like a god which correspondingly mean that they sought complete independence from Jehovah's sovereignty and so they were cast out of Eden. The consequences of their actions are manifested in human's lifetime dissatisfaction over their achievement which were handed from Adam to his descendant. Also, by implication, the first couple denies the position of being subordinated to God and forfeited their privilege to live forever [10]. Their disobedience interrupted the relationship between God and humans [11].

The length of years God allows Mankind to Govern Themselves

The literature [12] says God allows mankind's rebellion only for six thousand (6,000) years. But, in the content of the cited literature, it did not mention the Biblical basis for arriving with such length of years and it did not mention as to when will it start. Hence, such gap will be addressed in the context of this study.

The Benefits of Theocratic Government Restoration

The Theocratic government restoration message indicates many facets of one's life. Researchers may apply the biblical concepts of restoration to improved health and

wellness [13]. The restored Theocratic government will undo all the consequential damages brought by the rebellion of the first human couple. God's kingdom will bring magnificent blessings to the entire human race [8].

Review on Different Claims About the "Last Days"

Multiple attempts had been made about modelling the time frame of the last days. Most of these attempts were using one-point system estimation model. Literature [12] says that 1975 may be the possible end of the last days. There are other literatures [14,15] stating that the last days may be fully completed in 1844 or in 2000. Another literature [16] enumerated these possible years as 1993, 1995, 1996, 1998, 2000, 2002, 2010 and 2028. On the other hand, the literature [17] specified that it may be in 2060. Furthermore, in the context of this study, the interval estimation was used for year modelling instead of the one-point model of estimation.

III. METHODOLOGY

This study used the qualitative method of research. Content-analysis was used to analyze and to integrate the different literatures including the accounts of the Bible with an aim to construct the year estimation model of theocratic governmental restoration. The content analysis was performed in this study by using the conflation structure analogy expert-judgment. The conflation structure analogy expert-judgement is done by specifying the requirements and explanations in the methodology.

Specification of these requirements are sequentially stated below:

There are two sets of requirements in making the year estimation model of Theocratic governmental restoration.

The first set of requirements are mathematical skills about linear function, deciphering the year of Adam's creation and the year interval of his rebellion, and deciphering the total allowable year length limit of human rebellion against God's sovereignty.

The second set of requirements are deciphering the beginning year of the "last days" which is also known as the year of the installation enthronement of Jesus Christ and determining the span of years from the year of Christ's installation of his Kingship to the year of the "judgement day".

The linear function concepts. The concept of linear function has a variety of applicability. For example, the author [18] used the linear function of scalar field for electromagnetic representation. Linear function can also be used for time analysis. Specifically, this study used simple time analysis in determining the length of years when two-year references are known. Time analysis can also be used in determining the value of the unknown year reference when the other year reference and the length of years are known. Hence, time analysis in the context of this study is

used for chronological modeling and to decipher time variable using the Bible as the context of analysis. The linear function concept was also used to validate the claim of 4026 BCE as the year of Adam's creation and for constructing the different versions of confidence interval estimation model of theocratic governmental restoration.

The year of the Adam's creation. According to literature [19], the year when Adam created was 4026 Before Common Era (BCE). In the context of this study, the researcher had strategically subjected "4206 BCE" for content verification and for mathematical validation by using the concept of linear function. The researcher had identified the pertinent complications on the difficulty of using mathematical operations due to: (a) the Bible uses ordinal type of data for counting year and not the ratio type of data, (b) the Bible uses lunar method of counting years. Hence, cumulative errors are possible, (c) the timeline does not have a zero year.

The researcher used restoration method to solve the complication indicated as (a) and (c). The researcher converted the ordinal year into interval year by theoretically including zero in the timeline but would require an additional one year unit if the computation happens to be finding the CE reference year given with the BCE reference year and given with the length of years between those references or it would require a deduction of one year unit if the computation happens to be finding the BCE reference year given with the CE reference year and given with the length of years between those references. Furthermore, the researcher used the concept of Veadar as the intercalary month in the Hebrew calendar added seven times in 19 years. These considerations will make the mathematical computation possible with respect to the transitional difference from BCE to CE and vice versa.

Estimating the year interval of Adam's rebellion. After the identification and revalidation in the year of Adam's creation (4206 BCE), then it would become easier to estimate the year interval of Adam's rebellion by using Genesis 6:3. Then, the researcher used the logical proposition that Adam had committed sin first before he became father to Seth and used his age-related information (130) as the basis of analysis by enumerating 130 list of possibilities.

The Total allowable year length limit of human rebellion. The researcher used the literatures [12,16] stating that human rebellion will only last for 6000 years long. However, the researcher had reconsidered the Biblical basis for such claim by using Leviticus 25:10-13 to determine the length of the Jubilee year, by using John 8:34-36 and Romans 6:6, 16; 7:14 to associate the concepts of slavery of sins and Jubilee year, by using Matthew 24:37-39 and Genesis 6:3, to associate Jesus' prophecy about the judgement that will take place in last days and the judgement that has happened in days of Noah. Lastly, the researcher made use to treat the 120 years mentioned in Genesis 6:3 as 120 Jubilee years with the

theoretical assumption that the initial judgement and the final judgement are relevantly related.

The beginning of the "last days". The literatures [20, 21] had presented the updated explanation of the computation of the beginning year of the last days and found it to be 1914 CE. The researcher had verified the Biblical basis for such computation and found it to be substantial.

The Span of years from the beginning and the end of the "last days". The researcher had used two possible options for the span of years. The first option was 107.5 years while the second option was 120 years. The predictive model of this year span is proposed to start at 1914 CE. The researcher had discussed it thoroughly in section IV.

IV. RESULTS AND DISCUSSION

The discussion of the results is thematically presented. The discussion has five main parts. The first part answers the question as to what form of government should Adam and Eve have had before the event of their rebellion. The second part answers the question about the consequences of the rebellion of Adam and Even for them and for us. The third part answers how long God will allow humankind to govern themselves. The fourth explains the benefits when theocratic government is restored. Lastly, this study highlights the proposed theocratic governmental restoration model with respect to time.

The form of government before the event of the rebellion of Adam and Eve

Hypothesis 1: The form of government before the event of the rebellion in the garden of Eden was the initial stage of Theocratic form of government.

Sources of Evidence: Genesis 2: 15-17; Genesis 3: 1-3.

Quotation, explanation, and analysis of the evidence: Genesis 2:15-17 says, "*Jehovah God took the man and settled him in the garden of Eden to cultivate it and to take care of it.*"¹⁶ *Jehovah God also gave this command to the man: "From every tree of the garden you may eat to satisfaction.*"¹⁷ *But as for the tree of the knowledge of good and bad, you must not eat from it, for in the day you eat from it you will certainly die."*

The command was initially given to Adam and then later to Eve as it was indicated at Genesis 3:1-3. Jehovah God wanted to teach both Adam and Eve that the continuity of human existence is highly dependent on their obedience of God's guidance and His rulership and it is something to be valued as higher than their physical sustenance. Such idea is validly supported in Acts 5:29, 1 Samuel 15: 22 & 23, Deuteronomy 11:13-15, Jeremiah 10:23 and Matthew 4:4. The cited scriptural bases boiled down in the superlative importance of God's rulership, which can also be labelled as the Theocratic form of government. It is sad to note,

though, that both Adam and Eve intentionally did not recognize the importance of such teaching pertaining to the rightfulness of God to rule over them because they disobeyed the first given commandment for them by God. Hence, the Theocratic form of government was halted by the moment when Adam and Even rebelled against the Creator. So, it leads to a new set of question as to the consequence of their rebellion.

The consequences of the rebellion of Adam and Eve

Hypothesis 2: The rebellion of Adam and Eve resulted to human suffering that will consistently lead to death and descended imperfection to their offspring.

Sources of Evidence: Genesis 3: 16-19, Romans 8:20-22, and Romans 5:12.

Quotation, explanation, and analysis of the evidence:

Genesis 3:16-19 says ¹⁶ *To the woman he said: "I will greatly increase the pain of your pregnancy; in pain you will give birth to children, and your longing will be for your husband, and he will dominate you."*¹⁷ *And to Adam he said: "Because you listened to your wife's voice and ate from the tree concerning which I gave you this command, 'You must not eat from it,' cursed is the ground on your account. In pain you will eat its produce all the days of your life. ¹⁸ It will grow thorns and thistles for you, and you must eat the vegetation of the field. ¹⁹ In the sweat of your face you will eat bread until you return to the ground, for out of it you were taken. For dust you are and to dust you will return."*

The scriptures in Genesis 3:16-19 specifically states the consequence of the rebellion of Adam and Eve. The Creator, Jehovah God, explained to them that they would suffer all the days of their lives, which would eventually lead to their death because they despised the original arrangement of God in taking care of them. The consistent content validation of this consequence is also mentioned in Romans 8:20-22 and in Romans 5:12.

Romans 8:20-22 states ²⁰ *For the creation was subjected to futility, not by its own will, but through the one who subjected it, on the basis of hope²¹ that the creation itself will also be set free from enslavement to corruption and have the glorious freedom of the children of God. ²² For we know that all creation keeps on groaning together and being in pain together until now."*

It is mentioned in verse 22 that all creation kept on groaning and being in pain together until now which initially have started during the rebellion of Adam and Eve. But such suffering will not continue forever because God has arranged a system to save the offspring of Adam and Even from the consequences of their rebellion. Hence, this will lead to the third set of question as to how long God would allow humankind to govern themselves.

The length of years God allows mankind to govern

Hypothesis 3: God allows humankind to govern themselves only for 6000 years from the year of Adam's rebellion.

Sources of Evidence: 6000 years span of human rebellious history (Proclaimers, chapter 8 pages 90-107); The Jubilee year is the national law of Israel that demands freedom from any form of slavery (Leviticus 25:10-13); The association of freedom from slavery of sins with the Jubilee year (John 8:34-36, Romans 6: 6, 16; 7:14); The association of the "last days" and Noah's day (Matthew 24:37-39 and Genesis 6:3).

Explanation and analysis of the evidence: Many Christians shared the belief that the Thousand Year Reign of Christ would follow (after) the 6,000 years of human rebellion [12, 16]. What are the biblical bases as to why mankind's form of government will last only up to 6000 years? The biblical bases are Genesis 6:3, Matthew 24:37-39, and Leviticus 25:10-13. These scriptures will be explained later as to why.

The Bible states that the sin entered because of Adam's rebellion. On the other hand, the restoration of the perfect human condition will be made possible through the act of justification which is also based on law (Romans 5:12-21; 1 John 3:8). Since, the entire race of humankind has been slave to sin and the only law in the entire Bible that speaks out of freedom from slavery was the concept of Jubilee year, then humankind needs the grand application of the Jubilee year. The natural concept of the Jubilee year takes place every 50th year, counting from Israel's entry into the promise land to express appreciation of their freedom from being slaves from Egypt and from any form of slavery (Leviticus 25:10-13). If the concept of the Jubilee year will be applied in a grander scale not just for being slaves of Egypt but as being slaves of sin, then its length shall be 6000 years. The basis is explained further as follows:

Jesus Christ said that the conclusion of the system of things was associated with the days or time of Noah (Mathew 24: 3, 37). The association does not limit only on human conditions and behavior between the last days and the day of Noah but includes the nature of time itself pertaining to the conclusion of its days. Hence, Genesis 6:3, which was about the judgement of Noah's day has something to do with the judgement that will take place in the last days as mentioned by Jesus Christ himself (Mathew 24: 3-37).

Genesis 6: 3 says, *"Then Jehovah said: "My spirit will not tolerate man indefinitely, because he is only flesh. Accordingly, his days will amount to 120 years."*

This implies that the 120 years shall be treated as 120 jubilee years to determine the length of years of the grand application of jubilee years with reference to humans' freedom from being slaves of sin. This further implies that

120 jubilee years is equivalent to 6000 years. (Solution: $120 \times 50 = 6000$). Therefore, God allows humankind's rebellion to exist only for 120 jubilee years, which is equivalent to 6000 years.

The benefits of Theocratic government restoration

Hypothesis 4: The restoration of Theocratic government will permanently solve all causing death human problems and will process the restoration of human perfection.

Sources of Evidence: 1 Corinthians 15:22-28 and Revelation 21:3-5, Revelation 20:4-10.

Explanation and analysis of the evidence:

1 Corinthians 15:22-28 states *"²² For just as in Adam all are dying, so also in the Christ all will be made alive. ²³ But each one in his own proper order: Christ the first fruits, afterward those who belong to the Christ during his presence. ²⁴ Next, the end, when he hands over the Kingdom to his God and Father, when he has brought to nothing all government and all authority and power. ²⁵ For he must rule as king until God has put all enemies under his feet. ²⁶ And the last enemy, death, is to be brought to nothing. ²⁷ For God "subjected all things under his feet." But when he says that 'all things have been subjected,' it is evident that this does not include the One who subjected all things to him. ²⁸ But when all things will have been subjected to him, then the Son himself will also subject himself to the One who subjected all things to him, that God may be all things to everyone."*

The cited scriptures sequentially explained that all forms of human government will be replaced by God's government and it will eliminate all the consequential causes of death from the result of the first existed human rebellion against God's authority until the full order of restoration of God's original design for His creation will be completed. The eradication of causing death consequences of Adam's independence is validated at Revelation 21:4 and 5 when it says that mourning, pain, and death will be no more, which will take place only if God will execute His right to rule over humankind's affair. It should be noted that Jehovah God will use His appointed firstborn son, Jesus Christ to eliminate the man-made government as stipulated in 1 Corinthians 15:22-28 and will restore order within one thousand years as stipulated in Revelation 20:4-7.

Hence, the restoration of the perfect state of human condition is processed within one thousand year of Jesus Christ reign during the imprisonment of Satan. Next, Satan will be set free for a moment to be allowed to influence humankind's affair even during the time that these people are already under the millennial reign of Jesus Christ, for which it will be called the second and the last rebellion that can ever happen in the history of mankind with respect to Theocratic governance. Then, the annihilation of Satan and all rebellious persons who intentionally rebelled against God's Theocratic government will be subjected to God's final clearing operation. For such reasons, the sequence of

the events can now be constructed to explain the confidence interval estimation model of Theocratic governmental restoration as shown in the next theme.

The Theocratic governmental restoration: interval estimation model

Based on the answers among the four research objectives, then the fifth objective can be made which is the Theocratic governmental restoration model with respect to time as displayed in Figure 1. The confidence interval estimation model of Theocratic governmental restoration is a model that depicts the consolidated sequence of the historical and futuristic events of humankind's conditions in relation to God's Theocratic form of government.

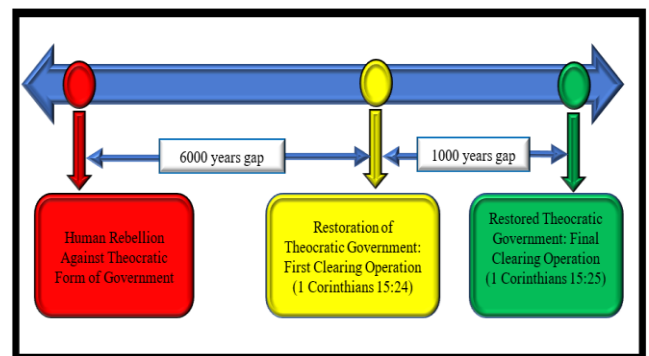

Figure 1. Interval Estimation Model Version 1

It also shows the gaps of time between important events. For example, there is a 6000-year gap from the rebellion of Adam and Eve against God's form of government to the execution of Jehovah's right to rule over the earth by the representation of Jesus, which will require full annihilation of human governments. Then, it will be followed by 1000 years of restoration of human perfection leading to the final event of the final clearing operation.

What makes the model important? It can serve as basis for in-depth Biblical analysis in relation to the detailed specification of Biblical events from the book of Genesis to the book of Revelation for predictive purposes. The model can also help the people to understand as to where they are in the stream of time in relation to God's judgement day. This will help anyone searching for Biblical truths to visualize the reality of God's promises with respect to time. Hence, the Theocratic form of government gives real hope to entire human race.

The Figure 2 shows the detailed model with respect to time about God's Theocratic governmental restoration which are constructed by answering the two added research questions, namely: (1) What year was Adam created by the Creator? (2) What year did Adam and Eve rebel against God's right of rulership? If these questions are answered, then, we can improve the Theocratic Governmental restoration model with respect to time as displayed in Figure 2.

The hypotheses 5 and 6 are proposed answers to the extended questions.

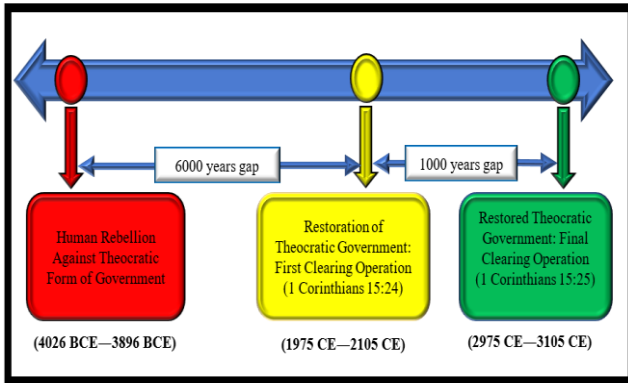

Figure 2. Interval Estimation Model Version 2

Hypothesis 5: The year of Adam’s creation was 4026 B.C.E.

Sources of Evidence: Volume 1 of Insight, Chronology, Biblical Count of time pages 458-464 and Genesis 5:3.

Explanation in the computation of 4026 BCE as the year of the creation of Adam: It was known that Adam was created during the year of 4026 BCE. The documented process of such computation is found on pages 458 to 464, Insight on the Scriptures, Volume 1. The researcher personally scrutinized the computation and found it to be valid. The mathematical skills to be used for such validation requires the usage of the distance formula or the concept of linear function in the reckoning of time. The reason why the researcher used the distance formula because there is a need to reconstruct the ordinal usage of time to ratio and because time is normally in a ratio level of measurement.

To understand strategically the contents of the Insight Book, there are three important things to understand.

First, it shall be noted that there is distinction in the usage of Before Common Era (B.C.E.) and Common Era (C.E.). For example, the next year of 5 B.C.E. will be 4 B.C.E. while the next year of 5 C.E. will be 6 C.E. Hence, the numerical representation of B.C.E. decreases while the numerical representation of C.E. increases as time moves forward. Second, the BCE-CE system of time does not have a zero year. For example, what year will it be after 1 B.C.E? The answer is not 0 B.C.E nor 0 C.E. The correct answer is 1 C.E. Lastly, the evidence of the continuity of time needs to be sequentially connected with Biblical evidence with respect to time to arrive with the accurate length of years. Hence, the last important thing is to know the total length of years that had passed since the year of Adam’s creation. To illustrate the third important information, Figure 3 has been provided.

In Figure 3, the **A** is the representation of the year of Adam’s creation, while the **d** is the total length of years that had passed since the year of **A**.

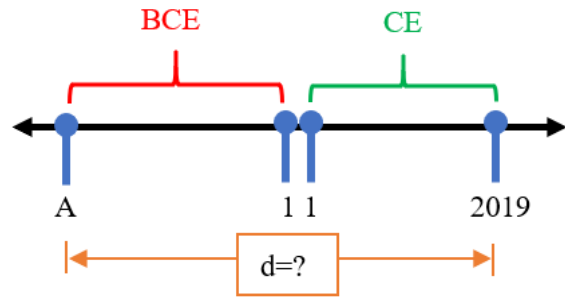

Figure 3. Linear Graphical Model in Reckoning Years

As based on Figure 3, if “**d**” will be known, then the equivalence of “**A**” can be deciphered. For you to understand the Biblical basis in the computation of the value of “**d**”, then further reading of this long-documented evidence is required. You may search it by reading the book, entitled “Insight on the Scriptures Volume 1, page 459 to 464.” The value of “**d**”, which is the total length of years from 2019 CE to the year of Adam’s creation, is 6044. Thus, the year of Adam’s creation should be 4026 BCE. The mathematical solution is $2019 - 1 - 6044 = -4026$. Since, there is no negative year, that is why BCE was used, which made it as 4026 BCE. The reason why negative one (-1) was an element in my solution because there was no zero year and the solution used was ratio level of measurement and not as an ordinal. That means the length of 1 BCE to 1 CE, in continuous form of data, was supposedly 2 years. But, because there was no zero year in the timeline, then the excess of one year shall be removed from the continuous solution.

The alternative solution for this is to divide the value of **d** into three segments. The first segment is between 2019 (CE) to 1 (CE). The second segment is between 1 (CE) to 1 (BCE). The last segment is between 1 (BCE) to **A** (BCE). The first segment has a year length of 2018 (Solution: $2019\text{ CE} - 1\text{ CE} = 2018$). The second segment has a year length of 1 (Solution: $1\text{ CE} - 1\text{ BCE} = 1$). The length of the year from 1 CE to 1 BCE is only 1 year because there was no zero year from 1 BCE and 1 CE. Lastly, the third segment has a year length of 4025 (Solution: $2018 + 1 + x = 6044$). The length year of the third segment is dependent on the totality of years of all the three segments equated to “**d**”. This means that the equation can be defined by adding the three segments of years. This implies that the first segment of year will be added by the second and third segments of years (represented by **x**) and these are equated to 6044. To solve for **A**, the solution is $A - 1 = 4025$. The final equation in solving for **A** is: $A = 4025 + 1 = 4026$.

Therefore, it is evidently shown that Adam was created at the year 4026 BCE.

At this moment, it is easier to estimate the year of Adam’s rebellion by considering the next hypothesis.

Hypothesis 6: The year of Adam’s rebellion had happened in the year interval of 4026 B.C.E. to 3896 B.C.E.

Sources of evidence: Volume 1 of Insight, Chronology, Biblical Count of time, pages 458 – 464 and Genesis 5:3.

Explanation and analysis of the evidence: The generation of hypothesis 6 is composed of two parts, as indicated below.

Part 1: The determination of the year of Adam's existence as presented in hypothesis 5 which took place in the year 4026 B.C.E. can be used as the initial reference in the year of Adam's rebellion to attain the safest estimation model.

Part 2: Explanation in the computation of 3896 BCE is extracted from Genesis 5:3. (The upper limit of the year of the rebellion of Adam)

Genesis 5:3 says, "Adam lived for 130 years and then became father to a son in his likeness, in his image, and he named him Seth."

The account of Genesis 5:3 is very important to determine the upper limit of the year of Adam's rebellion. The scripture at Genesis 5:3 implies that there are maximum of 130 options in the list of possibilities in estimating the year of Adam's rebellion. The logical basis is dependent on the idea that Adam and Eve committed the sin first before he had the sons and daughters. This means that Adam rebelled against God at the age less than or equal to 130 years old. The list of implications are as follows:

It is possible that the event of Adam's rebellion happened at 4026 BCE when he was 1 year old.

It is possible that the event of Adams' rebellion happened at 4025 BCE when he was 2 years old.

It is possible that the event of Adam's rebellion happened at 4024 BCE when he was 3 years old.

We can continue the structural logic until the enumeration of its last maximum list of possibility—*It is possible that the event of Adam's rebellion happened at 3896 BCE when he was 130 years old.*

Hence, the estimation of the year of Adam's rebellion had happened at the interval year of 4026 BCE to 3896 BCE.

Finally, we can now extend the analysis to obtain the full parametric view of the confidence interval estimation model of Theocratic governmental restoration by considering the generated knowledge of this study.

Generated knowledge: The theocratic governmental restoration will take place between the year interval of 1975 C.E. to 2105 C.E. for the first clearing operation while 2975 C.E. to 3105 C.E. for the second clearing operation.

Sources of evidence: The hypothesis 1, hypothesis 3, and hypotheses 5 and 6 are the sources of the evidence.

Explanation and analysis of the evidence: If it is true that "God allows mankind's rebellion to exist only for 6000 years because of the grand application of the Jubilee years in freeing mankind from the slavery of sins" and if it is true "that humankind's first rebellion had occurred during 4026BCE to 3896 BCE", then the completion of the grand application of the Jubilee year will take place between 1975 C.E. to 2105 C.E. which will also be the restoration of Theocratic form of government.

Hence, there will be 130 list of implications like shown below:

- 1) 6000 years after 4026 BCE was 1975 CE. This is the first possible implication.
- 2) 6000 years after 4025 BCE was 1976 CE. This is the second possible implication.
- 3) 6000 years after 4024 BCE was 1977 CE. This is the third possible implication.
- 4) 6000 years after 4023 BCE was 1978 CE. This is the fourth possible implication.
- 5) 6000 years after 4022 BCE was 1979 CE. This is the fifth possible implication.
- 6) 6000 years after 4021 BCE was 1980 CE. This is the sixth possible implication.
- 7) 6000 years after 4020 BCE was 1981CE. This is the seventh possible implication.
- 8) 6000 years after 4019 BCE was 1982 CE. This is the eighth possible implication.
- 9) 6000 years after 4018 BCE was 1983 CE. This is the ninth possible implication.
- 10) 6000 years after 4017 BCE was 1982 CE. This is the tenth possible implication. Continue the logic until we reach on the 130th possible implication...
- 130) 6000 years after 3896 BCE will be 2105 CE.

Therefore, the estimated model of God's theocratic restoration after 6000 years will be between 1975 C.E. to 2105 C.E. On the other hand, the result of the counting of the 1000 years after 1975C.E.—2105 C.E. will be 2975 C.E. and 3105 C.E.

The generated knowledge of this study is somewhat neighborly consonant with the study made by Isaac Newton when he said that the memorable date of apocalypse will end before A.C. 2060 [17]. My theory is also somewhat relevant to the study made by Nardotto when he says that the more accurate result of the calculation of the eventual end of time on the earthly affair reaches its summit in the year 2028 AC [16]. Their one-point system estimation falls within the interval system estimation in this study, which is [1975 CE, 2105 CE]. However, the essence derived from this study is different from their study because this study does not pronounce a literal end of the human existence but rather a freedom from the condition of being slaves of sins and a restoration of the Theocratic form of government.

Furthermore, the generated knowledge can still be enhanced by considering the Biblical accounts at Genesis 2:19-20.

Genesis 2:19, 20 states “19 Now Jehovah God had been forming from the ground every wild animal of the field and every flying creature of the heavens, and he began bringing them to the man to see what he would call each one; and whatever the man would call each living creature, that became its name. 20 So the man named all the domestic animals and the flying creatures of the heavens and every wild animal of the field, but for the man there was no helper as a complement of him.”

This implies that Adam had not yet committed the sin when he was 1 year old. Such work as mentioned in Genesis 2: 20 may require longer years to complete, since his task was to name all kinds of animals. This further implies that the estimated year of Adams’ rebellion 4026 BCE – 3896 BCE can still be improved. Thus, a third version model can still be constructed. Figure 4 shows the version three of the confidence interval estimation model of Theocratic governmental restoration.

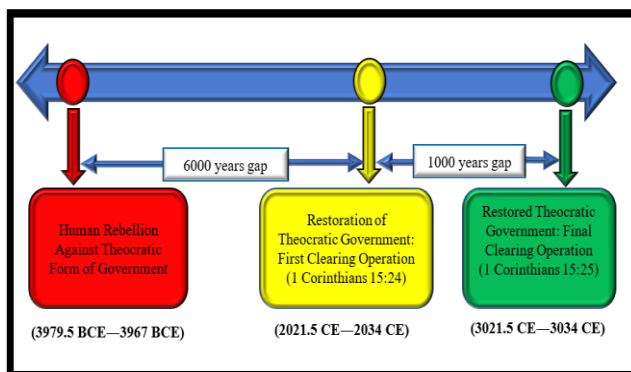

Figure 4. Interval Estimation Model Version 3

The derivation of the third version model would require additional questions such: (3) At what year did Jesus Christ installed as God’s appointed King? (4) At what year will Jesus Christ execute judgement over the Earth from the year of his installation as God’s heavenly King?

The construction of hypotheses 7 and 8 are the proposed answers to the extended question as to what year did Jesus installed as God’s appointed King and at what year will Jesus Christ execute judgement over the Earth from the year of his installation as God’s heavenly King.

Hypothesis 7: The year of Jesus Christ’s installation as God’s heavenly King is 1914 CE.

Sources of evidence: What Can the Bible Teach us? Page 217-220.

Scriptural basis: Daniel 4:1, 10-16; 1 Chronicles 29:23; 2 Kings 25:1, 8-10; Ezekiel 21:25-27; Luke 21:24; Luke 1:30-33, Revelation 12:6-14, Numbers 14:34, and Ezekiel 4:6.

The explanation of the evidence: The content of the book “What Can the Bible Teach us”? explains well that 607 B.C.E. was the start of the *seven times* prophecy about

God’s installation of the chosen King, Jesus Christ. The equivalent of the *seven times* was amounted to 2,520 years. So, the completion of seven times from 607 BCE will be 1914 C.E. For the detailed explanation of such computation should be referred by reading the book entitled “What can the Bible teach us? On page 217 to 220.

Hypothesis 8: Jesus Christ will execute judgement over the Earth 107.5 years after the year of his Kingship installation.

Sources of evidence: Matthew 24:1-51. Specifically, Matthew 24:34; Genesis 15:14-16, Acts 7:6,7; Exodus 12:40,41; and Galatians 3:14-29, specifically Galatians 3:17.

Jesus Christ mentioned in Matthew 24:34 that the fulfilment of the restoration will occur even before the extinction of a certain generation. The meaning of the generation that will qualify in such context are those genuinely worshipping the true God, Jehovah, or God’s people. This is evident from Matthew 24: 3. The one who asked the question about the sign of Jesus Christ’s presence and the sign of the conclusion of the system of things were his disciples. Therefore, the extraction of the basis of analysis about the length of the generation mention in Matthew 24:34 shall be the generation of God’s people. In the entire contents of the Bible, only Exodus 12:40, 41, Galatians 3:17 and Genesis 6:3 have the actual and complete length of the generation that can be used to associate the freedom concept, namely, from the condition of being slave to freedom with the inclusion of Judgement.

Now, Exodus 12:40 & 41 and Genesis 15:16 mentioned that the actual length of four generations is 430 years. This implies that the length of one generation shall be 107.5 years by using the concept of ratio and proportion. If such length of the generation will be applied in the context of Matthew 24:3 and verse 34, then, it implies that 107.5 years after 1914 CE will be 2021.5 CE. This means that the fulfilment of the prophecy may require a length of 107.5 years for one generation from the sign of Jesus’ presence and the conclusion of the system of things.

Moreover, it should be noted that the main problem of the entire human race was rooted from the rebellion of Adam and Eve. Appropriately, it is safer to include Genesis 6:3 in constructing the estimation model in the conclusion of the system of things in the context of Matthew 24:34. This implies that there are two possible lengths of generation, namely, the 107.5 years and the 120 years.

Therefore, 107.5 or 120 years after 1914 will be 2021.5 CE to 2034 CE is, so far, the better estimation model of the conclusion of the system of things which happens to be in the parallel fulfilment of 1 Corinthians 15:24. These concepts can be used to improve the entire confidence interval estimation model of Theocratic governmental restoration by moving the 6,000 years backward and by moving 1000 years forward from 2021.5 CE—2034 CE. So, by moving 6,000 years backward from 2021.5

CE—2034 CE, then the result will be 3979.5 BCE—3967 BCE and by moving 1000 years forward from 2021.5 CE—2034 CE, then the result will be 3021.5 CE—3034 CE.

The 3979.5 BCE to 3967 BCE is the improved estimated year of Adam's rebellion which further implies that Adam was 46.5 to 59 years old when he rebelled against his Creator, Jehovah God (Solution for 46.5: $(-3979.5 - (-4026)) = 46.5$; Solution for 59: $(-3967 - (-4026)) = 59$).

Computation of theoretical accuracy of the confidence interval estimation model of Theocratic governmental restoration

The theoretical accuracy is dependent on the acceptance of the two assumptions. The first assumption is the correctness of the 4026 BCE as the year of Adam's creation while the second assumption is the correctness of the length of 6000 years as the total allowable years of human rebellion against God's sovereignty. By considering these assumptions, then, the theoretical rate of accuracy of the confidence interval estimation model (1975 CE to 2105 CE) of theocratic restoration will be measured as 100% because the 130 list of possibilities that are found in hypothesis 6 are fully utilized. On the other, the theoretical rate of accuracy of the confidence interval (2021.5 CE to 2034 CE) estimation model of theocratic restoration will be 98.82%. The solution for arriving with 98.82% is: $6000 - (2105 - 2034) \div 6000 = 98.82\%$.

V. CONCLUSION AND FUTURE SCOPE

Based on the data gathered from hypothesis 1 to 8 of this study, multiple conclusions can be made. The first conclusion is that Theocratic form of government was the original government intended for Adam and Eve. Second, the rebellion of the first human couple was the main reason of human suffering. Third, the human rebellion against God's sovereignty will last only for 6000 years and it may occur either on [1975 C.E. – 2105 C.E.] with 100% theoretical accuracy or on [2021.5 C.E. – 2034 C.E.] with 98.82% theoretical accuracy. The fourth conclusion is that the human perfection will be restored within the length of 1000 years of Jesus Christ's rulership which may also occur either on [2975 C.E. – 3105 C.E.] with 100% theoretical accuracy or [3021.5 C.E. – 3034 C.E.] with 98.82% theoretical accuracy. This means that God's rightfulness to rule over mankind's affair will theoretically take place either in the year interval of 1975 Common Era to 2105 Common Era or in the year interval of 2021.5 Common Era to 2034 Common Era as the manifestation of the grander application of the 120 Jubilee years, promising mankind's freedom from being slaves of sins.

ACKNOWLEDGMENT

I would like to acknowledge the faculties of Cebu Normal University under the program of Doctor of Philosophy Major in Research and Evaluation for helping me to

develop my skills on how to make a research paper pertaining to theory development. Special thanks also to Dr L. A. Novabos, Dr G. T. Tito, and Dr A.S. del Socorro for their full support pertaining to my research publication submission.

REFERENCES

- [1] J.A. Ocampo, "Just Security in an Undergoverned World," Oxford University Press, **United Kingdom**, pp. 3-13, 2018.
- [2] H. Kahn, "World Economic Development: 1979 and Beyond," Routledge, **USA**, pp. 59-70, 2019.
- [3] W. T. Bible and Tract Society of Pennsylvania, "Will We Ever Feel Safe and Secure," *Awake!*, No. 1, pp. 1-5, 2019.
- [4] M. Zuckerman, C. Li, E. Diener, "Religion as an exchange system: The interchangeability of God and government in a provider role," *Personality and Social Psychology Bulletin*, Vol. 44, Issue. 8, pp. 1201-1213, 2018.
- [5] G. Sher, "In Search of a Substantive Theory of Truth," *The Journal of Philosophy*, Vol. 101, No. 1, pp. 5-36, 2004.
- [6] D. H. Dunn, "Exiled from Eden An Exegesis of Genesis 3," *Academia*, pp. 1-20, 2018.
- [7] K.R. Hughes, "Genesis: Beginning and Blessing," Crossway Book, Wheaton, Illinois, pp.17-18, 2004.
- [8] W. T. Bible and Tract Society of Pennsylvania, "Lesson You Can Learn from the Bible," Watchtower Bible and Tract Society of New York, **USA**, pp. 10-15; 237-239, 2017.
- [9] P.W. Khan, "Out of Eden: Adam and Eve and The Problem of Evil," Princeton University Press, New Jersey, pp. 12, 2009.
- [10] B. Becking, "Out of Paradise: Eve and Adam and their interpreters," Sheffield Phoenix Press, pp. 8-13, 2011.
- [11] P. Shonebarger, "Bible prophecy: what did jesus, daniel, ezekiel, paul, and john teach about the end-times?," Zondervan Bible publishers, pp. 5, 2015.
- [12] W. T. Bible and Tract Society of Pennsylvania, "Say, What Does this 1975 Mean?," Proclaimers, New York, **USA**, pp. 104-105, 1993.
- [13] D.N.P. Tyron, "Biblical Concepts of Restoration as a Foundation for Lifestyle Change," *The Journal of Biblical Foundations of Faith and Learning*, Vol. 3 : Issue 1 , Article 28, pp. 1, 2018.
- [14] E.G. White, "The great controversy," Devoted Publishing Ontario Inc., **Canada**, pp. 156, 2017.
- [15] J. Kirsch, "A History of the End of the World: How the most controversial book in the Bible changed the course of western civilization," HarperCollins, **New York**, pp. 215, 2006.
- [16] D. A. Rivera and SQ Swan Sosity, "Final warning: A history of the new world order," InteliBooks Publishin, **USA**, pp. 503-511, 1997.
- [17] A. May, "Isaac Newton: Scientist," Cavendish Square Publishing, **New York**, pp. 88-89, 2017.
- [18] D.K. Bonello, Y. Iano, U.B. Neto, "Representation of a Gradient for Scalar Electromagnetic Field in MATLAB using Differential Operators," *International Journal of Scientific Research in Physics and Applied Sciences*, Vol.8, Issue.2, pp.10-14, 2020.
- [19] W. T. Bible and Tract Society of Pennsylvania, "Chronology," *Insight*. Vol. 1, pp. 459-464, 2018.
- [20] W. T. Bible and Tract Society of Pennsylvania, "What Does the Bible Really Teach?," Watchtower Bible and Tract Society of New York, pp. 215-218, 2014.
- [21] W. T. Bible and Tract Society of Pennsylvania, "What Can the Bible Teach Us?," Watchtower Bible and Tract Society of New York, pp. 217-220, 2015.

AUTHORS PROFILE

S. L. Nemenzo is a graduate of Bachelor of Secondary Education (CNC), Master in Science Teaching-Math (UC), and the Doctor in Development Education (CTU), all in the Philippines. He pursued the Doctor of Philosophy in Research and Education (CNU) for the purpose of developing his skills in development theory and in predictive modelling. His field of research interests are on mathematical and predictive modelling. He accepts academic related research consultation and has a total of 13 years teaching experience as a College instructor, as an International Math instructor, and as a public-school teacher. He is currently connected as a Senior High School Teacher in the Department of Education-Philippines, teaching Mathematics and Research related courses. His first published research paper was with International Journal of Scientific Research in Multidisciplinary Studies.