

Integrated Inertial Navigation System with camera-based system using LabVIEW Software

M. Raja^{1*}, Anmol Agarwal², Anushree Gautam³

^{1,2,3}Aerospace Engineering, UPES, Dehradun, India

*Corresponding Author: rajavionics@gmail.com, Tel.: +8938817363

Available online at: www.isroset.org

Received: 01/Feb/2020, Accepted: 11/Feb/2020, Online: 28/Feb/2020

Abstract— This research exhibits an integrated Inertial Navigation System (INS) and a camera-based navigation system. The system contains three types of sensors such as A camera, capturing the terrain. The raw image data are fed into an image-processing algorithm, the output of which is a set of recognizable points in the image, An IMU (Inertial Measurement Unit) containing gyroscopes and accelerometers, magnetometer. The miniaturization, reduced cost, and increased accuracy of cameras and inertial measurement units (IMU) makes them ideal sensors for determining the 3D position and attitude of vehicles navigating in GPS-denied areas. In particular, fast and highly dynamic motions can be precisely estimated over short periods of time by fusing rotational velocity and linear acceleration measurements provided by the IMU's gyroscopes and accelerometers, respectively. The integration of the bias and noise in the inertial measurements can be significantly reduced by processing observations to point features detected in camera images in what is known as a vision-aided inertial navigation system.

Keywords—INS, IMU, 3D Position, Gyroscope, Accelerometer

I. INTRODUCTION

To combine camera-based navigation and INS in an integrated navigation system; through which we will obtain a system that unites:

- The precise measurement of high frequency motion that the INS delivers,
- The low position drift rate that the camera-based navigation offers.

The camera-based navigation system provides position measurement aiding to the INS. This is an alternative to the conventional GPS (Global Positioning System) assisted INS. GPS is vulnerable to jamming and other disturbances. Camera-based navigation cannot that easily be disturbed, and an INS is impossible to jam.

Inertial Navigation System (INS) is a computer based self-contained system that will provide aircraft's geographic information in terms of latitude and longitude with aircraft speed, heading and tracking information. Additionally it can also provide wind velocity and direction if we use True Air Speed (TAS) as an input value. In INS system, angular rate and specific force measurements from Inertial Measurement Unit (IMU) are processed to yield the position, velocity and attitude of the aircraft.

Inertial navigation is used during a wide variety of applications as well as the navigation of Aircraft, strategic missiles, Space-crafts, submarines, and ships. Recent advances within the construction of

Microelectromechanical devices have created it attainable to manufacture tiny and light-weight guidance systems [1], [2]. These advances have widened the range of possible applications to incorporate areas like human and animal motion capture.

II. RELATED WORK

To determine the position of an aircraft we need 2 accelerometers, one for the North-South direction and other for the East-West. Now with the help of these 2 sensors we will get our final position in reference to the initial position. Accelerometer should constantly remain horizontal to accurately measure the aircraft's acceleration. To maintain the accelerometer horizontal we use a Gyro-stabilized platform which is called INS.

INS requires the basic input values such as the initial position, GPS data, Pressure reading and the True Airspeed for wind speed. Before INS can work autonomously it requires an initialization process known as alignment. During alignment process the INS establish a relationship between aircraft's frame and the geographic reference of the aircraft. The time taken for the alignment process depends upon the accuracy it have. Some INS completes this process while they are in motion. They do this with the help of GPS. For the rest of the system we have to manually enter the initial positions. The aircraft of remain stationary during this procedure because a slight movement can disturb the final outcome if the INS is the sole mean of navigation in the aircraft [3].

Quadcopters are type of multi rotor helicopter that are lifted and propelled by 4 motors. They use 2 pairs of identical fixed pitched propellers to generate lift, in which 2 are clockwise and other 2 motors rotates anticlockwise direction. By changing the speed of each rotor it is possible to specifically generate a desired total thrust, to locate for the center of thrust both laterally and longitudinally and to create a desired total torque, or turning force. At a small size, quadcopters are cheaper and more durable than conventional helicopters due to their mechanical simplicity. Their smaller blades are also advantageous because they possess less kinetic energy, reducing their ability to cause damage.

The frame of our quadcopter is an Aluminum Fiber Glass frame of dimension 20*10*10 cm. We are using four 2800 KV brushless motors with 30 A of ESC (Electronic Speed Controller). An electronic speed control is used to vary a motor's speed, its direction and possibly also to act as a dynamic brake. ESCs are often used on motors essentially providing an electronically generated three-phase electric power low voltage source of energy for the motor.

The battery is of 3300 mAh with 2.4 GHz Flysky transmitters. The Heart of all Multirotors is the Flight Controller; this gives stabilization and control to all Multirotors. We are using APM 2.8 flight controller. Some of their features are:

- It supports two-way telemetry and in-flight command using the powerful MAVlink Protocol.
 - 4 MB of onboard data logging memory.
- Built-in hardware failsafe processor.

III. METHODOLOGY

At each time step, the INS computes an estimate of the vehicle position and attitude. Using these estimates together with the position of the landmarks to calculate predicted positions attitude carries out the integration with the camera-based navigation, and velocity estimates at high-rate. The difference between these predicted positions and the measured positions of the image tokens are used to estimate the INS errors.

Arduino code consists of a setup part and a loop, which runs continuously containing the calculations part. Xbee is used with "6 DOF" IMU sensors to get values of angles changed from initial position along all the three axis and angular velocities of the same. These values are used as input values to Arduino. Generally an IMU consists of an accelerometer, gyroscope, Pressure and magnetometer. The values read from these components are calibrated to get the desired sensor values [4].

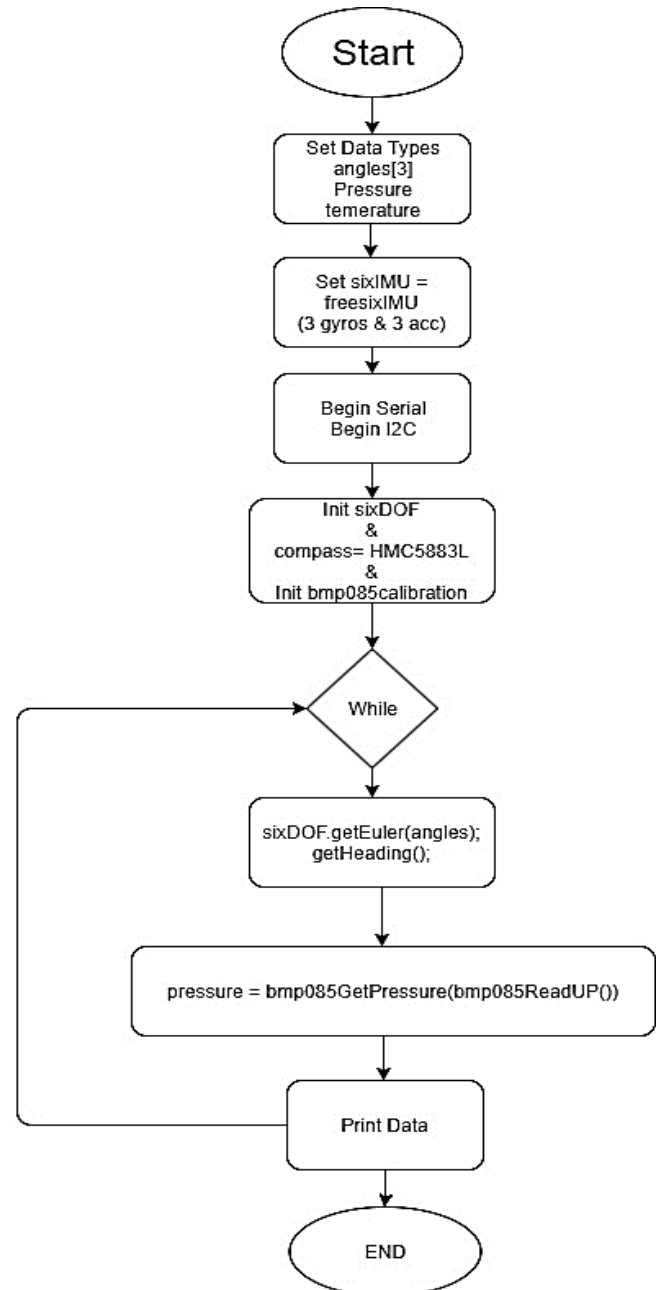

Figure 1. Flow charts for IMU

For IMU configuration with Arduino, firstly initialize the IMU libraries and I2C bus for data transmission. Then Data Types for Angles (3), heading, Temperature And Pressure are selected. Set the FreeSixIMU object of sixDOF. Record any errors that may occur in the compass and set it to zero. Now, Begin UART and I2C and set baud Rate to 9600. Then Initialize Acc and Gyro by sixDOF.init(); And Initialize compass by initializing HMC5883 [5].

Data Transmission to ground station is done by Xbee communication module that works on UART protocol. Pins 10 & 11 are used as RX and TX by softwareserial.h library and named as myserial. And then ports are set to begin with 9600 baud rate,

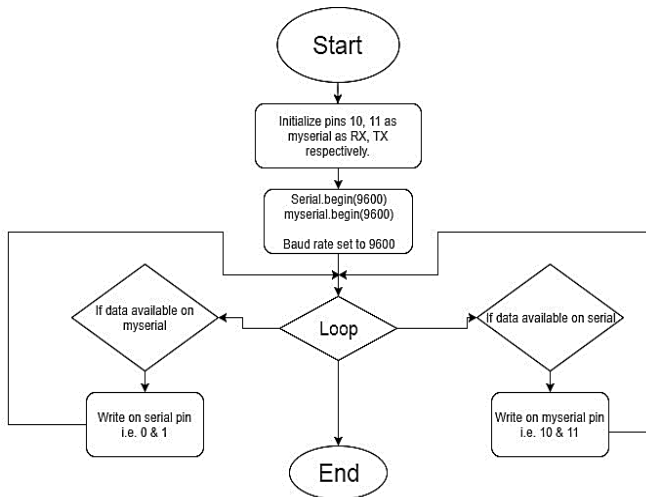

Figure 2. Flow charts for IMU

An infinite loop is generated in which data received from serial port is sent to myserial and vice versa. In this way, communication is done both by ground station to object And Object to Ground Station.

Inertial Measurement Unit (IMU)

Inertial Measurement Units (IMU) is a self-contained system that measures linear and angular motion usually with a triad of gyroscopes and triad of accelerometers. An IMU can either be gimbaled or strap down, outputting the integrating quantities of angular velocity and acceleration in the sensor/body frame. They are commonly referred to as the rate-integrating gyroscopes and accelerometers [6].

For our project we are using 06-DOF (Degree of Freedom) IMU. This inertial-measurement-unit combines 2 sensors to give you 06 axes of data, which are

- 3 axes of accelerometer data
- 3 axes gyroscopic

MPU6050 IMU sensor

The MPU-6050 is a motion processing technology. By combining a MEMS 3-axis gyroscope and a 3-axis accelerometer on the same silicon die together with an onboard Digital Motion Processor™ (DMP™) capable of processing complex 9-axis MotionFusion algorithms, the MPU-6050 does away with the cross-axis alignment problems that can creep up on discrete parts [5].

Its Features are:

- I2C Digital-output of 6 or 9-axis MotionFusion data in rotation matrix, quaternion, Euler Angle, or raw data format
- Input Voltage: 2.3 - 3.4V
- Selectable Solder Jumpers on CLK, FSYNC and ADO
- Tri-Axis accelerometer with a programmable full scale range of ±2g, ±4g, ±8g and ±16g
- Digital Motion Processing™ (DMP™) engine offloads complex MotionFusion, sensor timing synchronization and gesture detection
- Embedded algorithms for run-time bias and compass calibration. No user intervention required
- Digital-output temperature sensor

Arduino UNO

Arduino Uno is a microcontroller based on the Atmega 328P. It has 14 digital input/output pins,6 analog inputs,a 16MHz quartz crystal,a USB connection,a power jack,an ICSP header and a reset button.It contains everything needed to support the microcontroller; simply connect it to a computer with a USB cable or power it with a AC-to-DC adapter or battery to get started [6].

Table 1: Specifications of Arduino UNO

Operating Voltage	5V
Input Voltage	7-12V
Digital I/O Pins	14 (of which 6 provide PWM output)
PWM Digital I/O Pins	6
Analog Input Pins	6
DC Current per I/O Pin	20 mA
DC Current for 3.3V Pin	50 mA
Flash Memory	32 KB (ATmega328P) of which 0.5 KB used by bootloader
Length	68.6 mm
Width	53.4 mm
Weight	25 g

Communication system: XBee

Xbee are the modules providing wireless end-point connectivity to devices. For this we are using Xbee S68 module. This is the XBee WiFi Module with wire antenna from Digi. XBee WiFi embedded RF modules provide simple serial to IEEE 802.11 connectivity. By bridging the low-power/low-cost requirements of wireless device networking with the proven infrastructure of 802.11, the XBee WiFi creates new wireless opportunities for energy management, process and factory automation, wireless sensor networks, intelligent asset management and more. Focused on the rigorous requirements of these wireless device networks, the module gives developers IP-to-device and device-to-cloud capability [6].

XBee modules offer developers tremendous flexibility and are available in surface mount and through-hole form factors. The XBee WiFi shares a common footprint with other XBee modules. This allows different XBee technologies to be drop-in replacements for each other.As a member of the XBee family, the XBee WiFi combines hardware with software for a complete modular solution. XBee WiFi modules are designed to communicate with access points in existing 802.11 infrastructures.

Features of XBee S68:

- 3.3V @ 309mA
- 72Mbps Max data rate
- Antenna Type: Integrated Wire
- Fully FCC certified
- 4 12-bit ADC input pins
- 10 digital IO pins
- 13 Channels

I²C Protocol

The Inter-integrated Circuit (I²C) Protocol is a protocol intended to allow multiple “slave” digital integrated circuits to communicate with one or more “master” chips. Unlike the Serial Peripheral Interface (SPI) which is only intended for short distance communications within a single device, I²C is used for communications between sensors for data exchange. The IMU sensor communicates with the Arduino through the I²C protocol [5].

The I²C bus physically consists of 2 active wires and a ground connection. The active wires, called SDA and SCL, are both bi-directional. SDA is the Serial Data line, and SCL is the Serial Clock line. Every device hooked up to the bus has its own unique address, no matter whether it is an MCU, LCD driver, memory, or ASIC. Each of these chips can act as a receiver and/or transmitter, depending on the functionality. Obviously, an LCD driver is only a receiver, while a memory or I/O chip can be both transmitter and receiver. The I²C bus is a multi-master bus. This means that more than one IC capable of initiating a data transfer can be connected to it. The I²C protocol specification states that the IC that initiates a data transfer on the bus is considered the Bus Master. Consequently, at that time, all the other ICs are regarded to be Bus Slaves. As bus masters are generally microcontrollers, here for instance, the bus master is ArduinoUno. Likewise, the MPU sensor is the Bus Slave.

XCTU Display

XCTU is a free multi-platform application that enables developers to manage radio frequency (RF) modules through a simple-to-use graphical interface. The application includes embedded tools that make it easy to set up, configure, and test RF modules.

Some of the salient features of this platform are:

- Compatible with the most-used operating systems, including Microsoft Windows, Linux, and Mac OS.
- Automatically discover local and remote radio modules connected to your PC, regardless of their port connections or configured settings.
- Manage and configure multiple RF devices, including remote devices communicating with XCTU over the air.
- Visualize the topology of your RF networks, displaying all network nodes and connections graphically or in a table.

Use embedded tools to perform operations, from recovering modules to performing range tests.

HMC 5883L- Implementation

Honeywell's HMC5883L is a 3-axis magnetometer. Magnetometers have a wide range of uses. The most common include using the chip as a digital compass to sense direction or using them to detect ferrous (magnetic) metals. Magnetic fields and current go hand-in-hand, when current flows through a wire, a magnetic field is created. This is the basic principle behind electromagnets. This is also the principle used to measure magnetic fields with a

magnetometer [6]. The direction of Earth's magnetic fields affects the flow of electrons in the sensor, and those changes in current can be measured and calculated to derive a compass heading or other useful information.

Features of the HMC 5883L as stated in its datasheet:

- Three-Axis Magnetoresistive Sensors and ASIC in a 3.0x3.0x0.9mm LCC Surface Mount Package.
- 12-bit ADC Coupled with Low noise AMR Sensors Achieves 5 milli-gauss Resolution in |8| Gauss Fields.
- Built in Self-Test
- Low voltage operations (2.16 to 3.6V) and Low Power Consumption (100uA)
- I²C Digital Interface
- Lead free package construction
- Wide magnetic field range (+/-8 Oe)
- Software and Algorithm support available
- Fast 160 Hz Maximum output rate

Benefits of HMC 5883L:

- Small size for highly integrated products
- Enables 1 to 2 degree compass heading accuracy
- Enables low-cost functionality test after assembly in production
- Compatible for battery powered applications
- Two Wire Serial data interface
- Sensors can be used in strong magnetic field environments
- Compassing Heading, Hard Iron, Soft Iron and Auto-Calibration libraries available

Enables pedestrian navigation

IV. RESULTS AND DISCUSSION

The selection of various instruments have been done along with the initial testing phase of flying the quadcopter. The stability of the frame, working of the motors and the inter-compatibility of the various components used have been checked and performing to their maximum positive limit. The instruments pivotal to the actual pretense of this project have been selected such that they provide high accuracy while also not amounting to the budget being overshot. The particular models have been listed in the report along with the benefits provided by them in addition to these. Simulations of the instruments have been performed on respective softwares to provide figures and graphs and the following results have been obtained

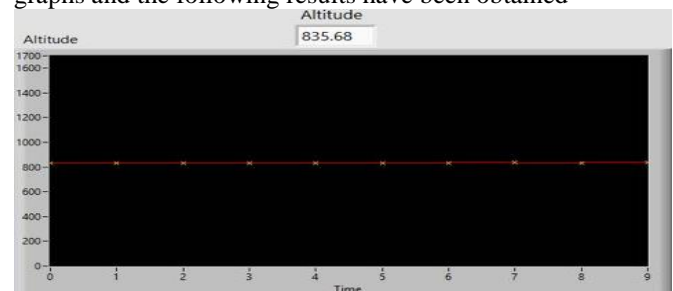

Figure 3. Quadcopter kept at almost 836m above mean sea level

Figure 3 shows the plot of a stationery quadcopter kept at almost 836m above mean sea level vs. time. The above graph has been obtained in a computerized display.

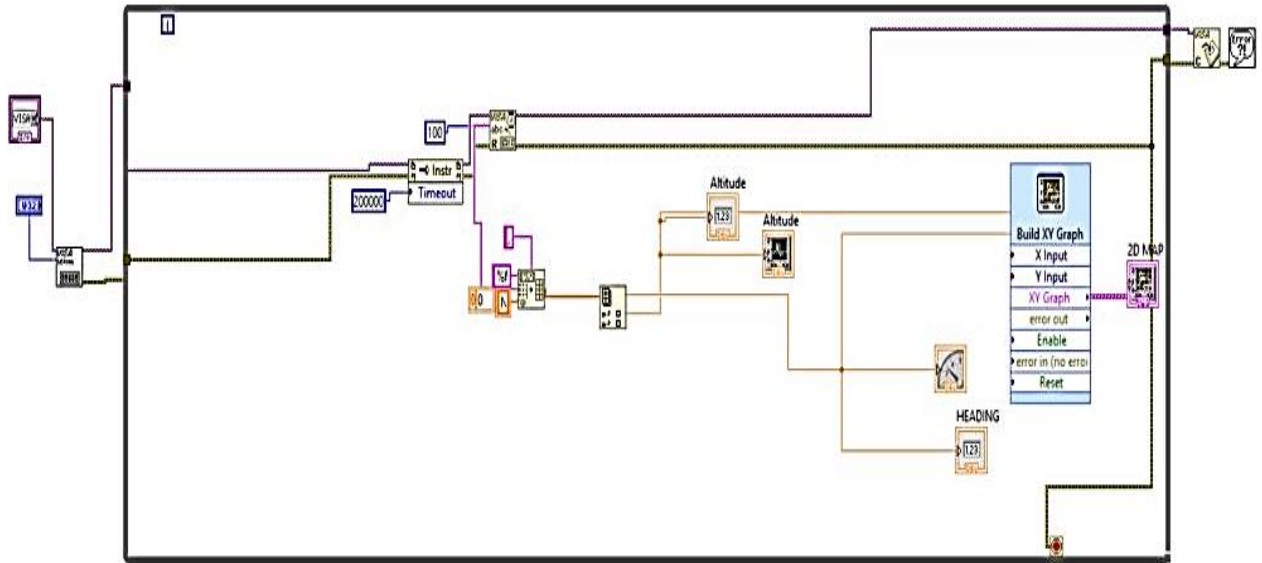

Figure 4. Integrated Sensor LabVIEW Circuit diagram

Table 2: Altitude (Alt) Vs Acceleration in x, y, z (Acx, Acy, Acz)

Alt	AcX	AcY	AcZ
850	412	316	18472
850.45	472	372	18497
850.42	344	367	18512
853.78	392	381	18526
856.69	380	394	18534
858.23	444	368	18549
860.72	488	392	18577
865.43	404	317	18602
871.54	408	328	18650
868.67	436	364	18612
864.39	496	387	18580
865.66	504	398	18592
867.14	500	394	18626
870.77	456	361	18664
875.33	492	378	18689
870.98	488	399	18638
862.7	448	366	18548
859.8	460	372	18502
855.52	404	312	18480
852.96	420	326	18477

Table 2. shows the readings obtained for a flight up to 870m above mean sea level, with the ground level at 850m above mean sea level. The readings for Altitude, Acceleration in 'x', 'y' and 'z' axes are obtained.



Figure 5. Altitude versus time graph

Figure 5 shows the plot of altitude versus time graph. Altitude is taken on y axis whereas time is along x axis.

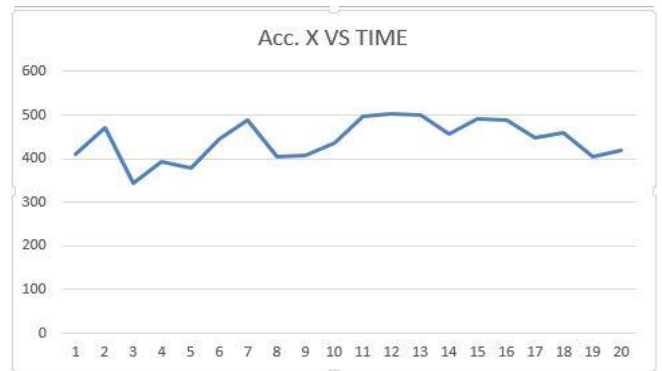
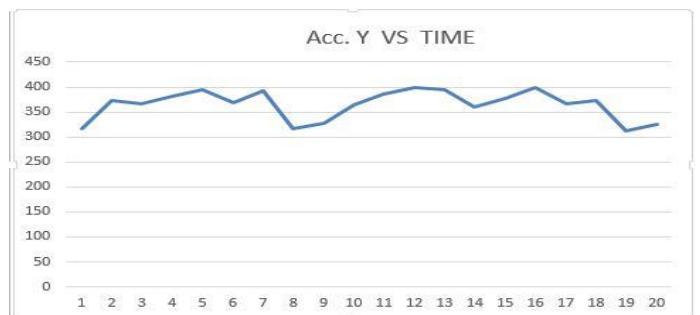
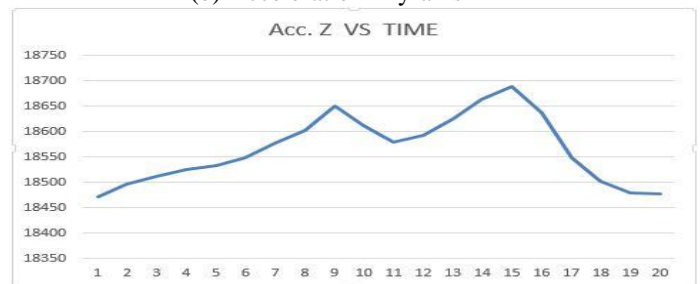

Figure 6. Acceleration in x-axis
Figure 6. (a) Shows the plot of Acceleration in x-axis versus time graph.



(b) Acceleration in y-axis



(c) Acceleration in z-axis

Figure 6. (b) & (c) Shows the plot of Acceleration in y-axis & z-axis versus time graph.

Therefore the result is obtained in the form plots of the different components of a flying Quadcopter. This enables us to send out unmanned air vehicles to GPS denied regions and fly the drone without many hassles. This also enables us to track the drone at any given point of time in order to avoid losing the drone.

V. CONCLUSION AND FUTURE SCOPE

To provide effective camera tracking and survey data of INS system, an attitude 850 m to 852m accuracy of less than 0.1 degrees and position accuracy of less than 1.0 meter. The integrated INS system must be extremely rugged to meet the demands of outdoor filming for land, water, and aerial camera platforms for higher altitudes.

ACKNOWLEDGMENT

We accept this open door to express our genuine gratitude to our mentor **Dr. Ugur Guven** for their direction and backing. We might likewise want to offer our thanks towards them for demonstrating trust in us. It was a benefit to have an extraordinary encounter working under him in a friendly domain.

We are grateful to our regarded resources to control us through any troubles we experienced. At last, we might want to recognize my folks, relatives. Without their help, this work would not have been conceivable.

REFERENCES

- [1] A. I. Mourikis and S. I. Roumeliotis, "A multi-state constraint Kalman filter for vision-aided inertial navigation," in *Proc. of the IEEE Intl. Conf. on Robot. and Automous.*, Roma, Italy, Apr. 2007, pp. 3565–3572.
- [2] D. G. Kottas, J. A. Hesch, S. L. Bowman, and S. I. Roumeliotis, "On the consistency of vision-aided inertial navigation," in *Proc. of the Intl. Sym. on Exp. Robot.*, Quebec, Canada, June 2012.
- [3] L. Meier, P. Tanskanen, F. Fraundorfer, and M. Pollefeys, "Pixhawk: A system for autonomous flight using onboard computer vision," in *Proc. of the IEEE Intl. Conf. on Robot. and Autom.*, Shanghai, China, May 2011, pp. 2992–2997.
- [4] E. S. Jones and S. Soatto, "Visual-inertial navigation, mapping and localization: A scalable real-time causal approach," *Intl. J. Robot. Research*, vol. 30, no. 4, pp. 407–430, Apr. 2011.
- [5] Bertozzi M., Broggi A., GOLD: A parallel real-time stereo vision system for generic obstacle and lane detection. *IEEE Trans. Image Process.* 1998;7:62-81.
- [6] Murray D., Little J.J. Using real-time stereo vision for mobile robot navigation. *Autonomous. Rob.* 2000;8:161-171.

AUTHORS PROFILE

Dr. M Raja had completed Bachelor of Engineering from Anna University of Chennai, 2006 and Master of Engineering from Madras institute of technology in year 2009. PhD Aerospace Engineering from UPES, Dehradun, 2019. He is currently working as Assistant Professor in Department of Aerospace Engineering, University of Petroleum and energy studies, Dehradun since 2012. He has published more than 20 research papers in international journals including Thomson Reuters and conferences including IEEE and it is available online. His main research work focuses on Control Algorithms, Navigation system, Guidance theory, Data acquisition based education. He has 10 years of teaching experience.

